

Food Warmer Parts Manual

FWH-1, FWH-2, Hatco, ThermoGlo

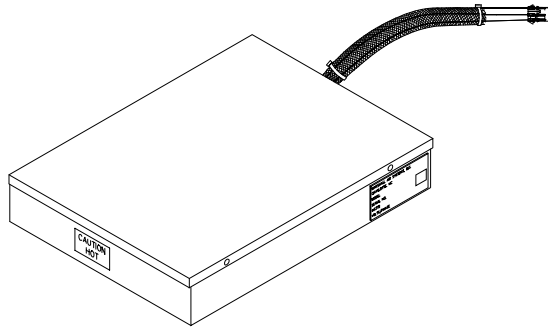
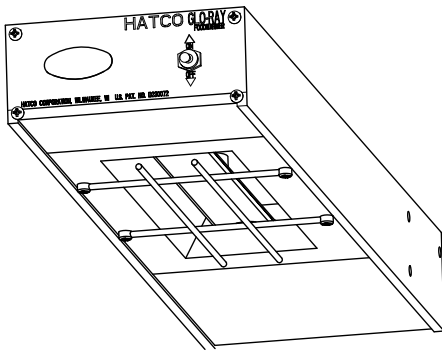
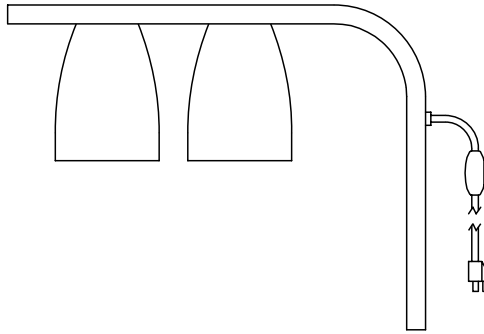
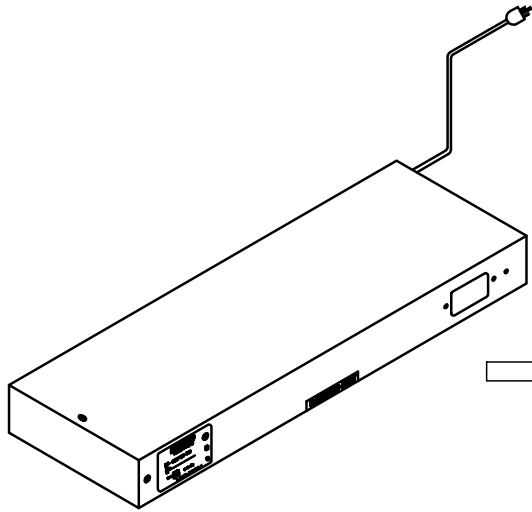

Frymaster, a member of the Commercial Food Equipment Service Association, recommends using CFESA Certified Technicians.

* 8196330 *

**24-Hour Service
Hotline 1-800-551-
8633**

OCT 11

NOTICE

IF, DURING THE WARRANTY PERIOD, THE CUSTOMER USES A PART FOR THIS MANITOWOC EQUIPMENT OTHER THAN AN **UNMODIFIED** NEW OR RECYCLED PART PURCHASED DIRECTLY FROM FRYMASTER/DEAN, OR ANY OF ITS AUTHORIZED SERVICE CENTERS, AND/OR THE PART BEING USED IS MODIFIED FROM ITS ORIGINAL CONFIGURATION, THIS WARRANTY WILL BE VOID. FURTHER, FRYMASTER/DEAN AND ITS AFFILIATES WILL NOT BE LIABLE FOR ANY CLAIMS, DAMAGES OR EXPENSES INCURRED BY THE CUSTOMER WHICH ARISE DIRECTLY OR INDIRECTLY, IN WHOLE OR IN PART, DUE TO THE INSTALLATION OF ANY MODIFIED PART AND/OR PART RECEIVED FROM AN UNAUTHORIZED SERVICE CENTER.

 DANGER

Copper wire suitable for at least 167°F (75°C) must be used for power connections.

 DANGER

The electrical power supply for this appliance must be the same as indicated on the rating and serial number plate located on the inside of the fryer door.

 DANGER

This appliance must be connected to the voltage and phase as specified on the rating and serial number plate located on the inside of the fryer door.

 DANGER

All wiring connections for this appliance must be made in accordance with the wiring diagrams furnished with the equipment. Wiring diagrams are located on the inside of the fryer door.

 DANGER

Do not store or use gasoline or other flammable vapors and liquids in the vicinity of this or any other appliance.

 WARNING

Do not use water jets to clean this equipment.

Table of Contents

Equipment	Page Number
FWH-1, Merco Rod-Style	1
FWH-2, Bulb Style	2
Hatco	3
ThermoGlo	4
Inserts, Pans: 35/45/55 Gas, RE Electric, Protector	5
Inserts, Pans: MJCF, Filter Magic	6
55 Cabinet	7
35/45 Cabinet	8
RE Cabinet	9
Casters/Legs/Anchors	10

Heat Lamps/Food Warmers

FWH-1, Merco Rod-Style

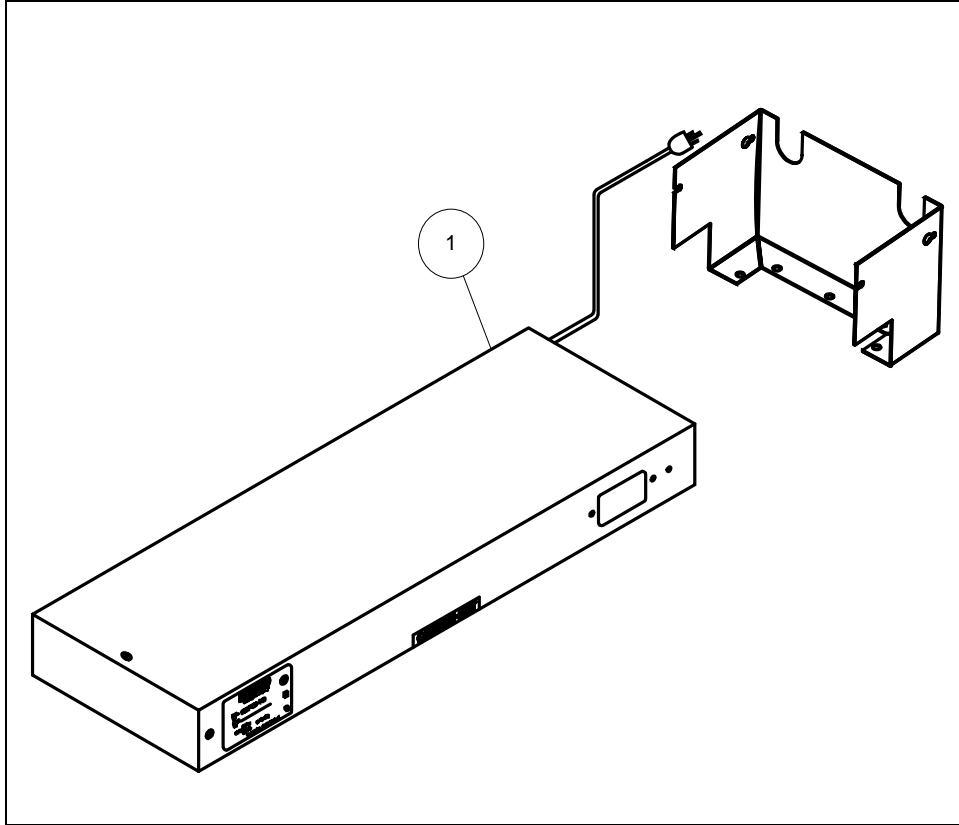

1	807-4356	Food warmer, 120/60 825W
*	807-4402	Food warmer, 240V
*	807-1413	120V Switch, toggle, ON/OFF
*	807-1414	240V Switch, toggle, ON/OFF
*	807-1416	Power on indicator light, red
*	807-1417	120V cordset, 3 wire
*	807-4358	120V Element (tube) heating, 20 1/4", 825W (screw-in)
*	807-4359	208/240 Element (tube) heating, 20 1/4" 825W (screw-in)
*	807-0746	120V Element (tube) heating, 20 1/4", 825W (snap-in)
*	807-0748	208/240 Element (tube) heating, 20 1/4" 825W (snap-in)
*	807-1415	Socket, heating rod (snap-in)
*	807-3783	Switch, Dean
*	826-0990	Hardware kit
*	810-2389	Holder, Quartz Lamp, (snap-in) Dean
*	210-5717	Bracket, Heat Lamp
*	210-5716	Mount, Heat Lamp

Heat Lamps/Food Warmers

FWH-2, Bulb Style

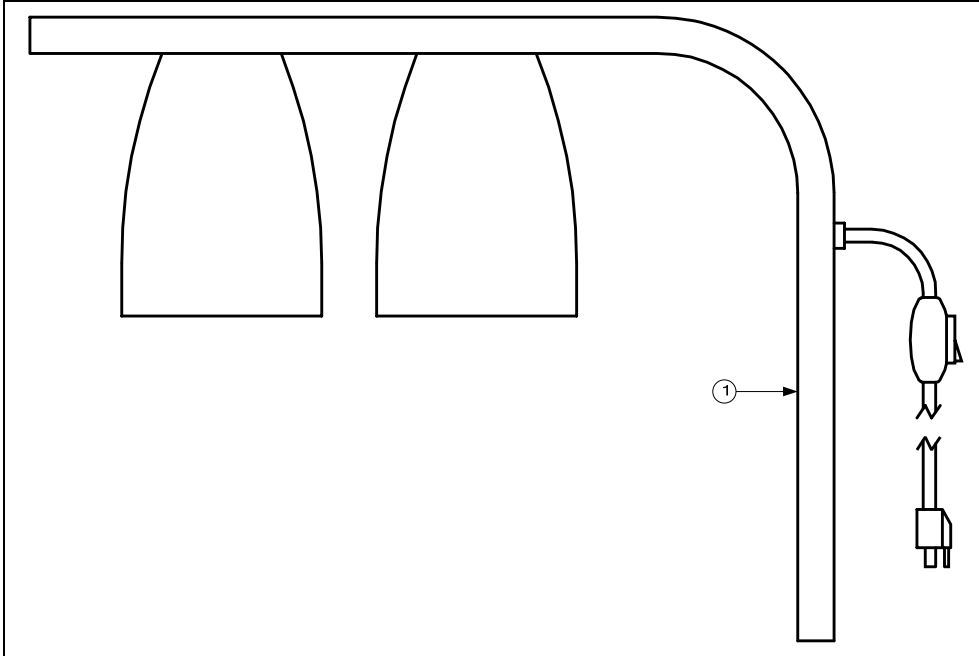

1	807-1575	120V Warmer, with support
*	807-1576	240V Warmer, with support
*	806-5278SP	120V Warmer kit, with mounting hardware
*	806-5285SP	240 Warmer Kit, with mounting hardware
*	807-3963	Socket, heating, bulb, 375W
*	807-3049	Bulb, 250W, 120V
*	807-3961	Bulb, 375W, 120V
*	807-3962	Bulb, 375W, 240V
*	826-1064	Hardware kit, (screws for attachment)
*	823-1896	Support, lamp, front/rear
*	807-3051	Cordset, in-line switch
*	826-1374	Screw, #10 (Qty:25)

Heat Lamps/Food Warmers

Hatco Warmers

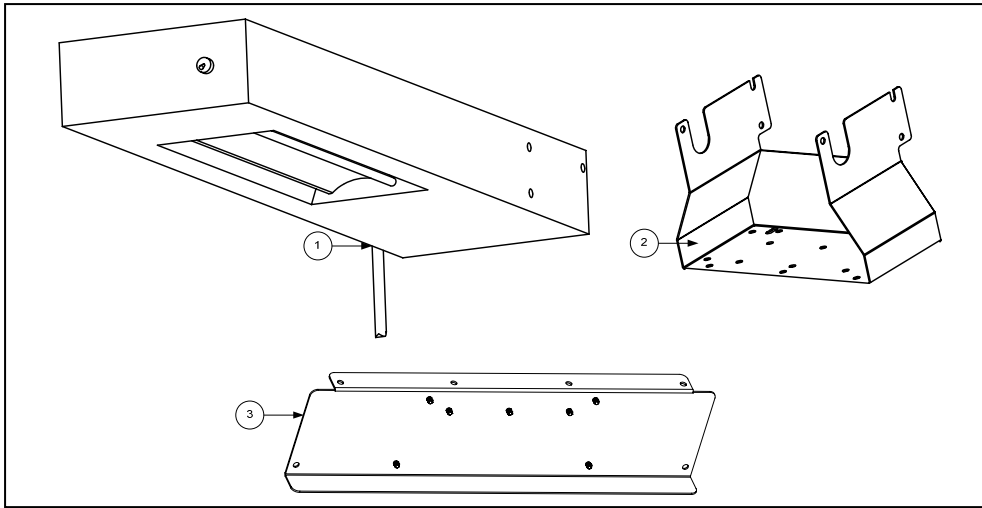

1	807-5104	120VAC Warmer assembly
*	807-5233	240V Warmer assembly
*	807-4696	230/240 CE Warmer assembly
2	824-2161	Hatco lamp mount
3	108-2069	35/45 Model Fryer Mounting Plate
*	108-2067	H55 Fryer Mounting Plate
*	108-2068	RE Electric Fryer Mounting Plate
*	826-3019	Mounting nuts, (Seven 8-32 acorn)
Dean Replacement Parts		
*	823-3963	Fryer Mounting Plate

Heat Lamps/Food Warmers

ThermoGlo Warmers

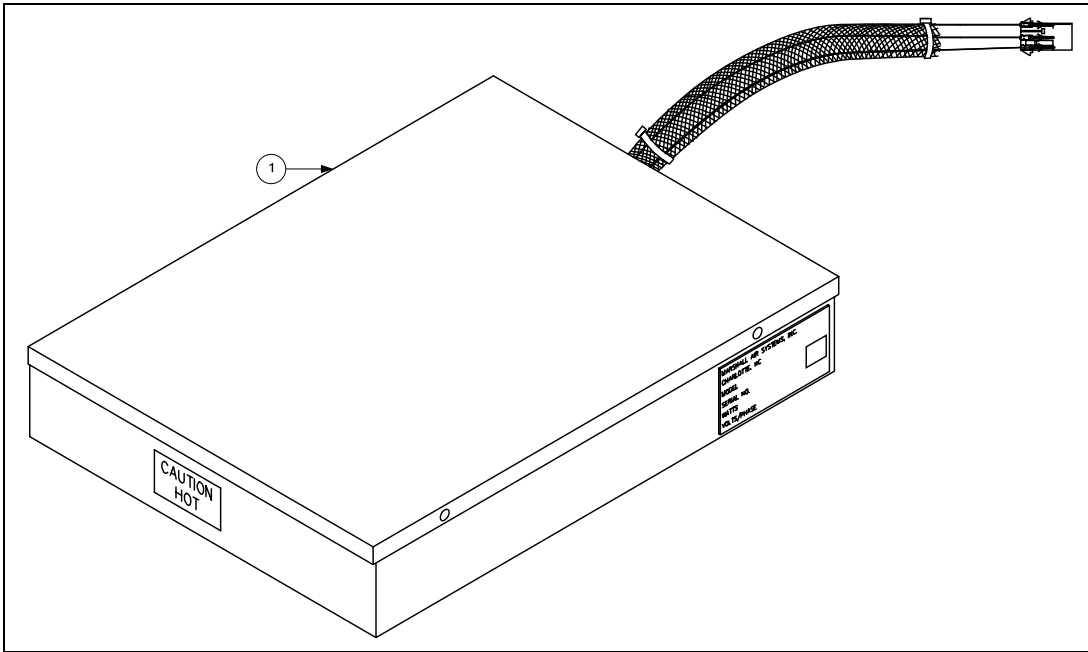

1	806-8836SP	120V Warmer
*	826-1279	120V Warmer kit
*	807-3353	240V Warmer
*	807-2082	Switch, rocker, power, ON/OFF
*	807-1041	Switch, toggle, power, ON/OFF
*	806-7732SP	Harness, wire

Heat Lamps/Food Warmers

Inserts/Pans 35/45/55 Gas Fryers and RE, Protector Electric Fryers

NOTE: Holding stations can be equipped with scoop or café pan holding areas. The inserts, which hold the pans in place, are different, depending on the style pan they hold. The inserts are also different for gas and electric fryers.

Café Pan Inserts

Café pan inserts have rounded corners

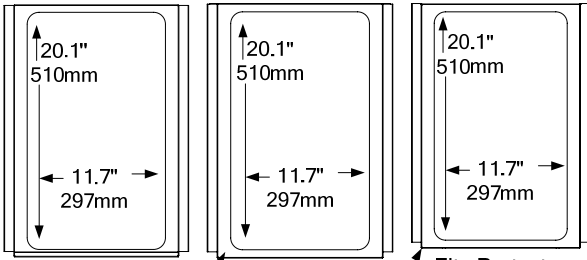

Fits 35/45/55 cabinets

Fits RE cabinets

Fits Protector Cabinets

230-6063

824-1662

824-1947

Café Pan Grate

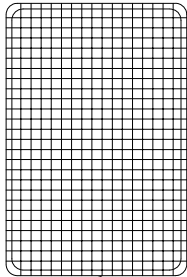

803-0104

Fits all café pan inserts

Café Pan

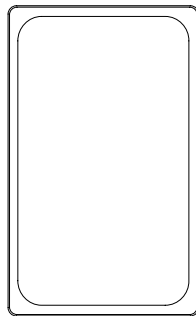

803-0054

Fits all café pan inserts

Scoop Pan Inserts

Scoop pan inserts have square corners

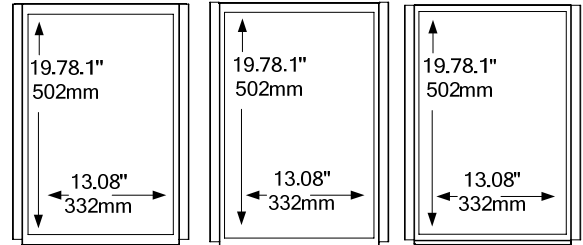

Fits 35/45/55 cabinets

Fits RE cabinets

Fits Protector cabinets

230-6064

824-1720

824-1948

Scoop Inset Pan

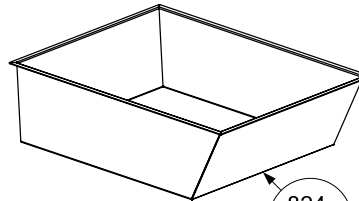

Fits all scoop inserts

824-1960

Scoop

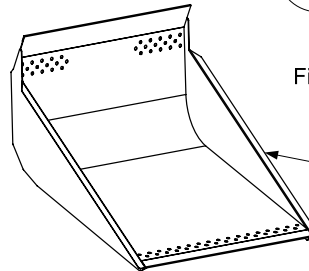

Fits all scoop inserts

823-1865

Cover

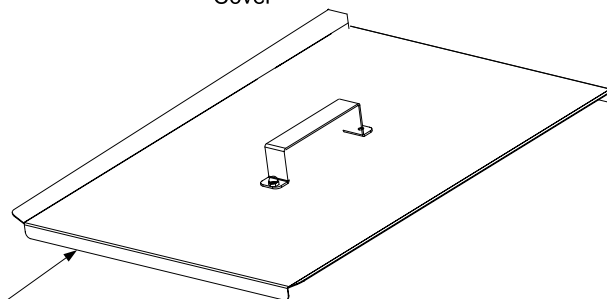

806-5518

Fits scoop or café pan

Heat Lamps/Food Warmers

Inserts/Pans MJCF/Filter Magic

NOTE: Holding stations can be equipped with scoop or café pan holding areas. The inserts, which hold the pans in place, are different, depending on the style pan they hold.

Café Pan Insert

Café pan inserts have rounded corners

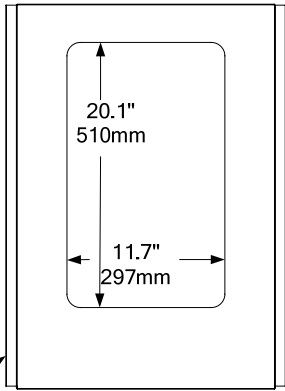

910-7704

Scoop Pan Insert

Scoop pan inserts have square corners

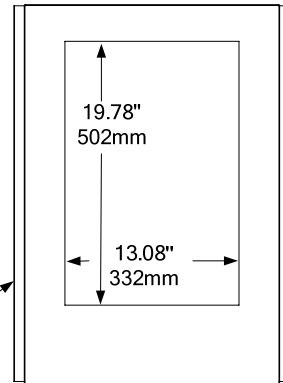

910-7705

Café Pan Grate

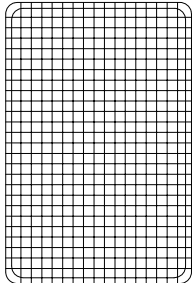

803-0104

Fits all café pan inserts

Café Pan

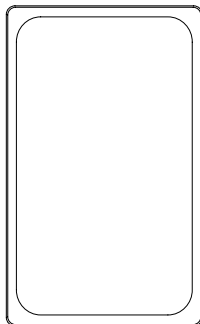

803-0054

Fits all café pan inserts

Scoop Inset Pan

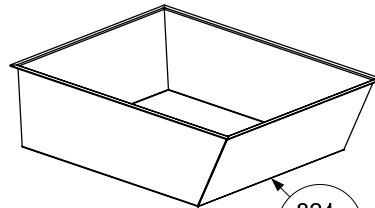

Fits all scoop inserts

824-1960*

*Earlier models used a different pan to store a powershower : 826-0993

Scoop

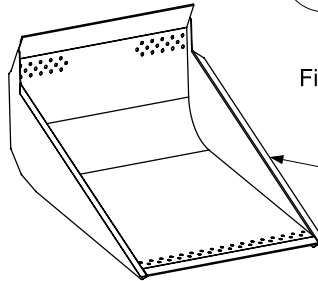

Fits all scoop inserts

823-1865

Cover

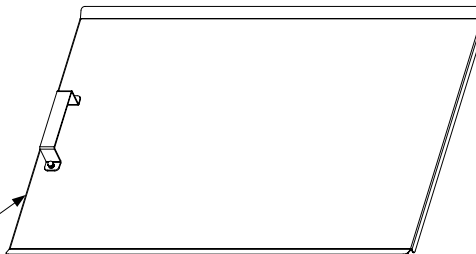

806-1343

Fits scoop or café pan

Heat Lamps/Food Warmers

55 Cabinets

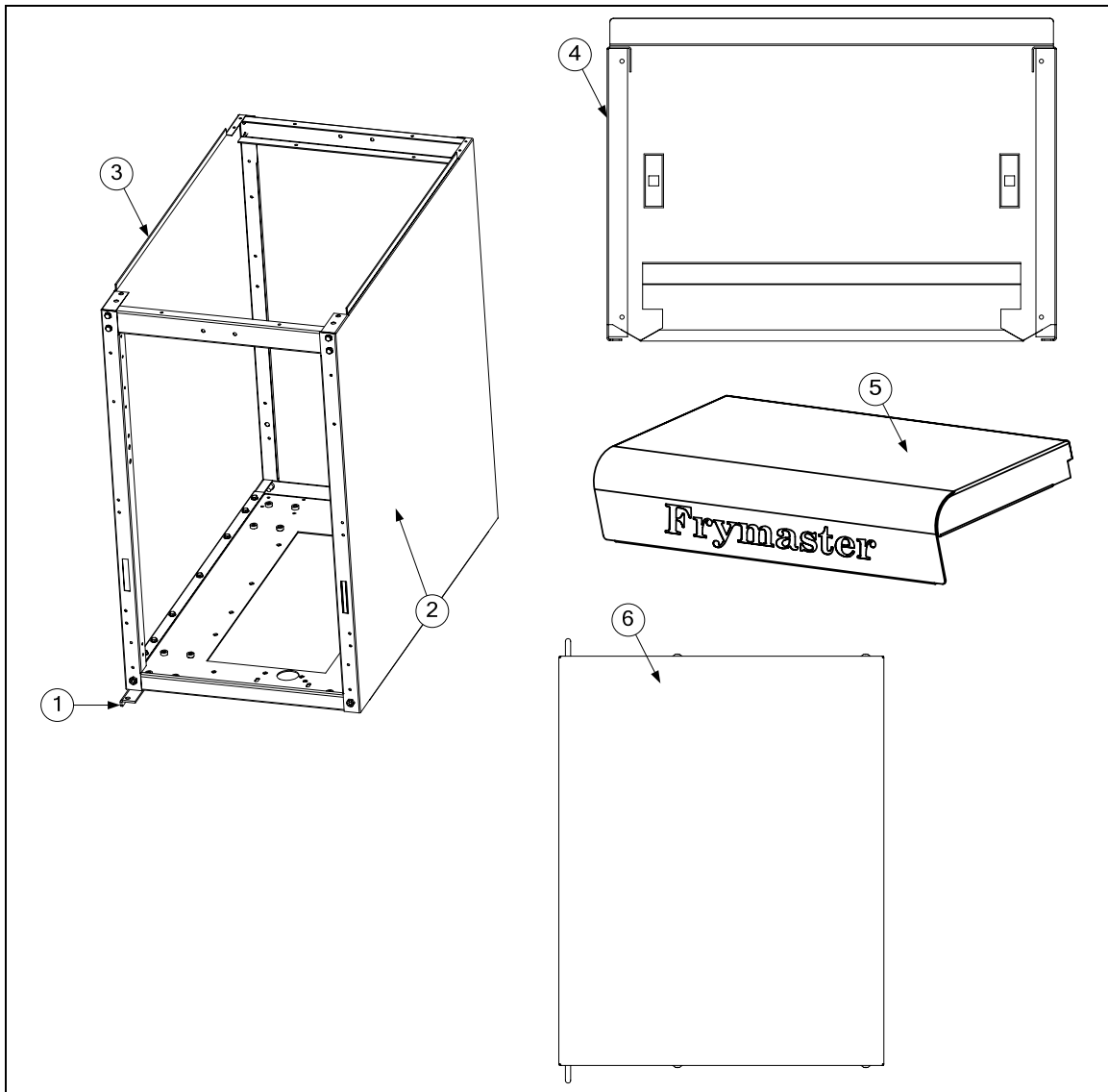

1	230-4685	Hinge, lower
*	106-5124	Base assembly
2	212-6510	Side, RT, stainless
*	202-6633	Side, RT, enamel
3	211-6510SP	Side, LT, stainless
*	201-6633SP	Side. LT, enamel
4	210-5969	Flue cap
5	824-1689	Top cap
6	106-4397	Door

Heat Lamps/Food Warmers

35/45 Cabinets

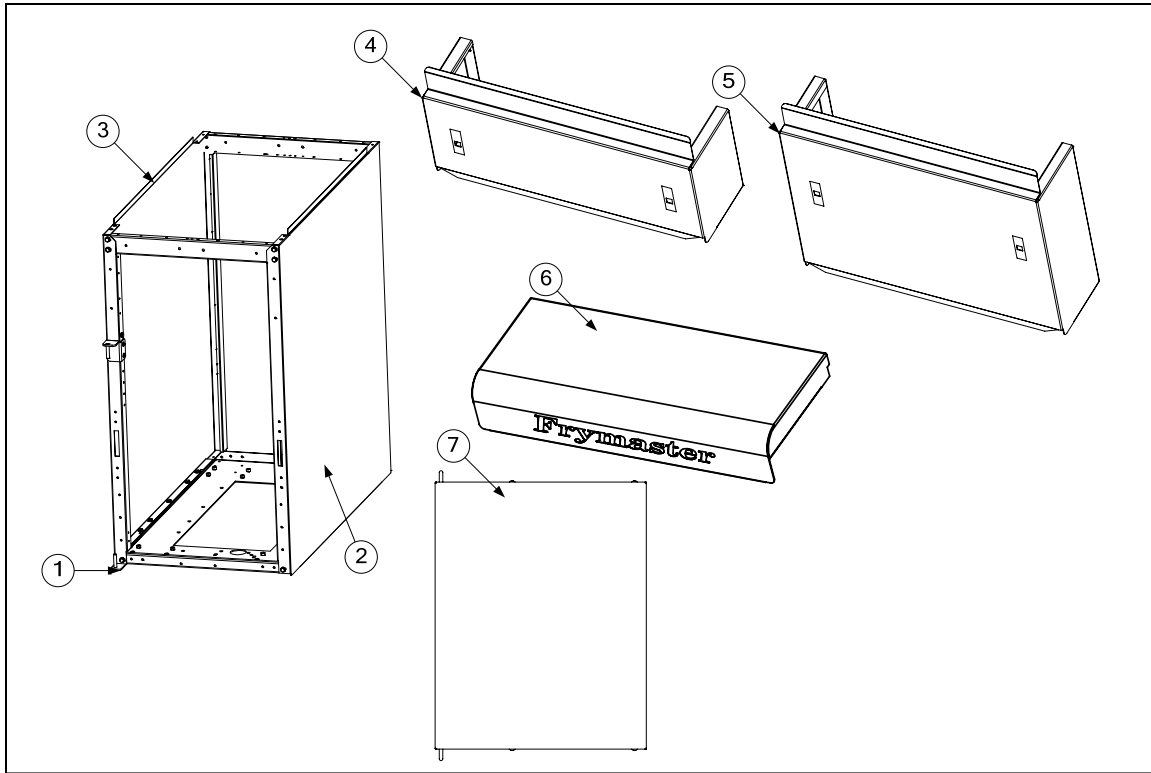

1	823-4713	Hinge, lower
*	106-5440	Base assembly
2	212-6893SP	Side, RT, Stainless
*	202-6917SP	Side, RT, enamel
3	211-6893SP	Side, LT, stainless
*	201-6917SP	Side, LT, enamel
4	210-6811	Flue cap, 35
5	210-6812	Flue cap, 45
6	824-1409	Top cap
7	106-9539	Door

Heat Lamps/Food Warmers

RE Cabinets

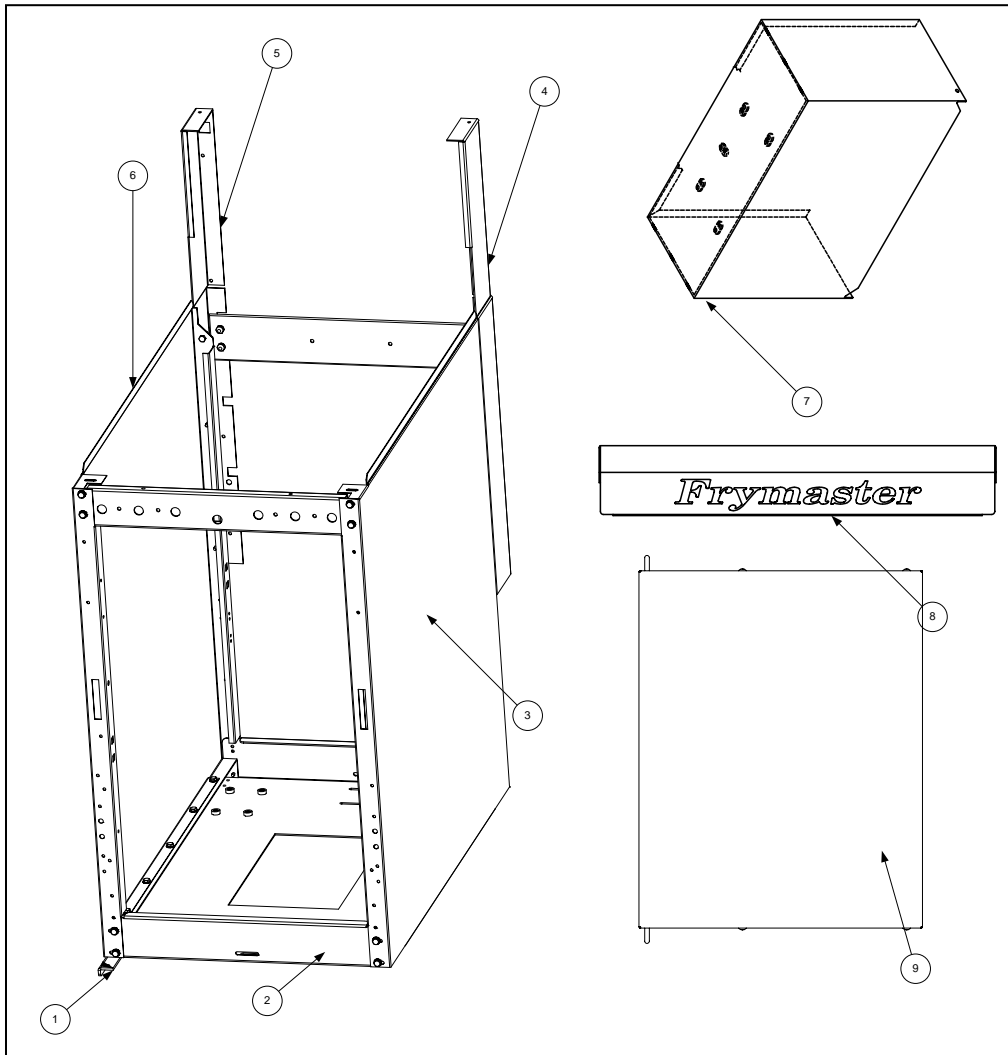

1	230-4685	Hinge, lower
2	106-4901	Base assembly
3	232-0323SP	Side, right SS
*	222-0323SP	Side, RT, enamel
4	106-3829	Upright assembly, RT
5	106-3828	Upright assembly, LT
6	231-0323SP	Side, left
*	221-0323SP	Side, LT, enamel
7	823-2358	Tilt housing
8	106-5195	Top cap
9	106-4397	Door

Heat Lamps/Food Warmers

Casters/Legs/Anchors

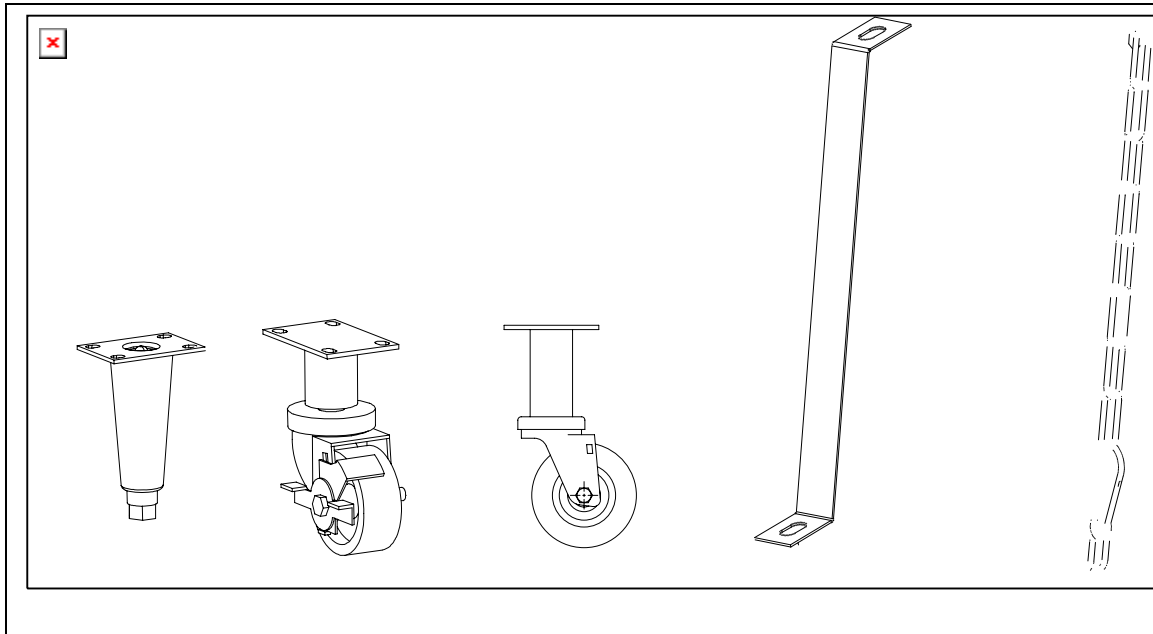

1	810-3169	Leg (set of 4)
2	810-0326	Caster, adjustable, with brake
3	810-1494	Caster, without brake
4	826-1095	Anchor restraint kit
5	826-0900	Chain restraint kit

Storage Pan

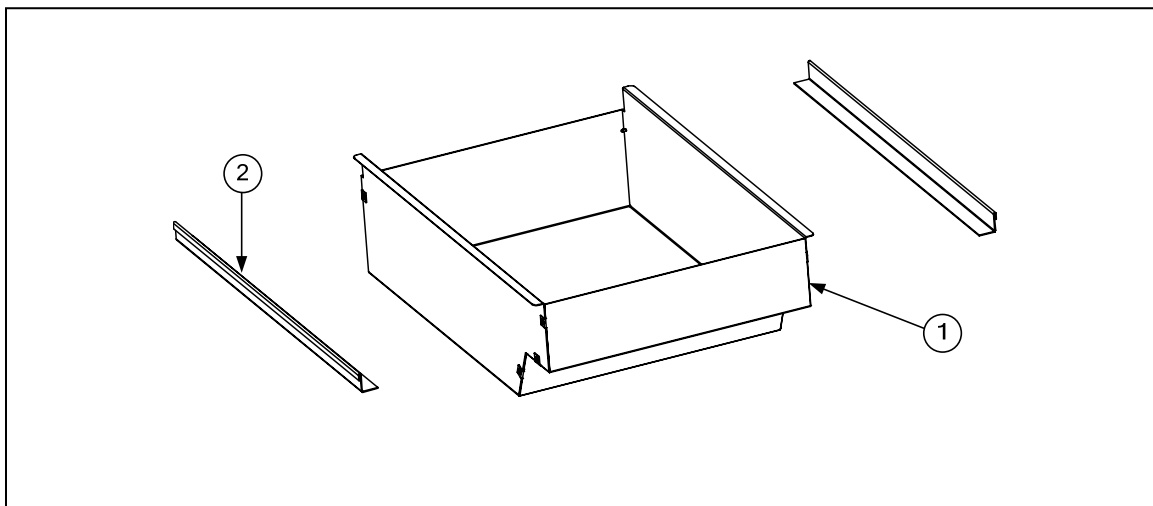

1	106-6829	Storage Pan
2	220-3229	Support Rails



Shipping Address: 8700 Line Avenue, Shreveport, Louisiana 71106

TEL 1-318-865-1711

FAX (Parts) 1-318-688-2200

(Tech Support) 1-318-219-7135

PRINTED IN THE UNITED STATES

SERVICE HOTLINE
1-800-551-8633

819-6330
OCT 11